

TELESCOPICMAST

THE MOBILE SECURITY BOX

The solid base for your mobile
surveillance unit



Content

Introduction	Page 01
Nice to meet you	03
The Mobile Security Box	05
MSB6 - Basic	11
MSB6 - Basic Plus	15
MSB6 - Premium	19
MSB - Premium XL	23
MSB - Compact	27
MSB - Roadbox	31
Specifications & Features	35
Mobile Security Box Trailers	39
Create your own solution	41
Branding possibilities	45

The Mobile Security Box

The solid base for your rapid deployment CCTV security solution

Lorem ipsum

In the dynamic world of security, where threats can evolve quickly, TelescopicMast provides reliable and resilient solutions. The Mobile Security Box is a versatile and adaptable security tower that seamlessly adjusts to meet your specific needs. With its adjustable height ranging from four to nine metres, this state-of-the-art tower grants unparalleled surveillance coverage, enabling security companies to safeguard sites, projects and events quickly and efficiently. Compatible with all major surveillance equipment manufacturers, this tower empowers you to build customised security solutions to your clients specific needs.

Our Mobile Security Box is ready for stand-alone applications when equipped with attachable solar panels and the installation of fuel cells inside the cabinet.

Partner with TelescopicMast and experience the pinnacle of security with our Mobile Security Box – your reliable partner for rapid deployment solutions.





Nice to meet you...

Your trusted partner in mobile security solutions!

At TelescopicMast, we specialise in advanced rapid deployment security towers for the evolving security industry.

Our team comprises skilled product designers, an international sales and customer services team, and efficient logistics and administration professionals. We are committed to putting our customers first. Our masts and trailers, designed for surveillance and monitoring, are crafted by experts who prioritise reliability and cutting-edge features.

With an international sales team attuned to your unique needs, we aim to provide solutions that exceed expectations.

Behind the scenes, our logistics and administration team ensure seamless operations from order through to delivery.

At TelescopicMast, we're dedicated to building lasting relationships by consistently delivering top-notch security masts coupled with a customer-centric focus.



As Co-founders of TelescopicMast, we take pride in our journey since 2018. TelescopicMast is honoured to be the trusted partner for over 150 clients across 20+ countries in the CCTV surveillance and rapid deployment solutions market.

Our commitment to innovation and reliability is evident in our purpose-built CCTV towers and the groundbreaking Mobile Security Box, designed to surpass industry standards. With high-quality masts, rigorously tested and TÜV Rheinland certified, we ensure both cutting-edge solutions and safety.

Serving diverse sectors, from security to military, TelescopicMast excels in many critical applications. The Mobile Security Box's compatibility with major surveillance equipment allows for bespoke solutions, empowering our clients to meet specific needs.

As we forge ahead, our dedication to excellence, quality, and client success remains unwavering. Thank you for choosing TelescopicMast.

Sincerely, Frank Aben and Henk de Haan

Frank Aben

Co-founder | Product Director



Henk de Haan

Co-founder | CEO



The Mobile Security Box

Temporary, fast and secure protection

Protect people, sites and assets

Mobile Security Boxes are used for the protection of unmanned sites, temporary installations and supporting on-site, manned guarding.

The market for temporary and rapid deployment CCTV systems is growing fast. Savings of 60% can be made over manned guarding costs and intruders can be detected quickly. Minimising damage, loss or delays in ongoing projects.

Typical applications include:

- Improving safety at major events, festivals, concerts & public gatherings
- Construction and industrial site security
- Roadside and traffic monitoring
- Protecting vacant properties
- Protecting infrastructure
- Reducing cable and metal theft
- Wind and solar farm security
- Crime hotspots such as car parks or isolated locations
- Preventing and minimising fire risk
- Monitoring railroad tracks



60%
costs savings
over manned
guarding

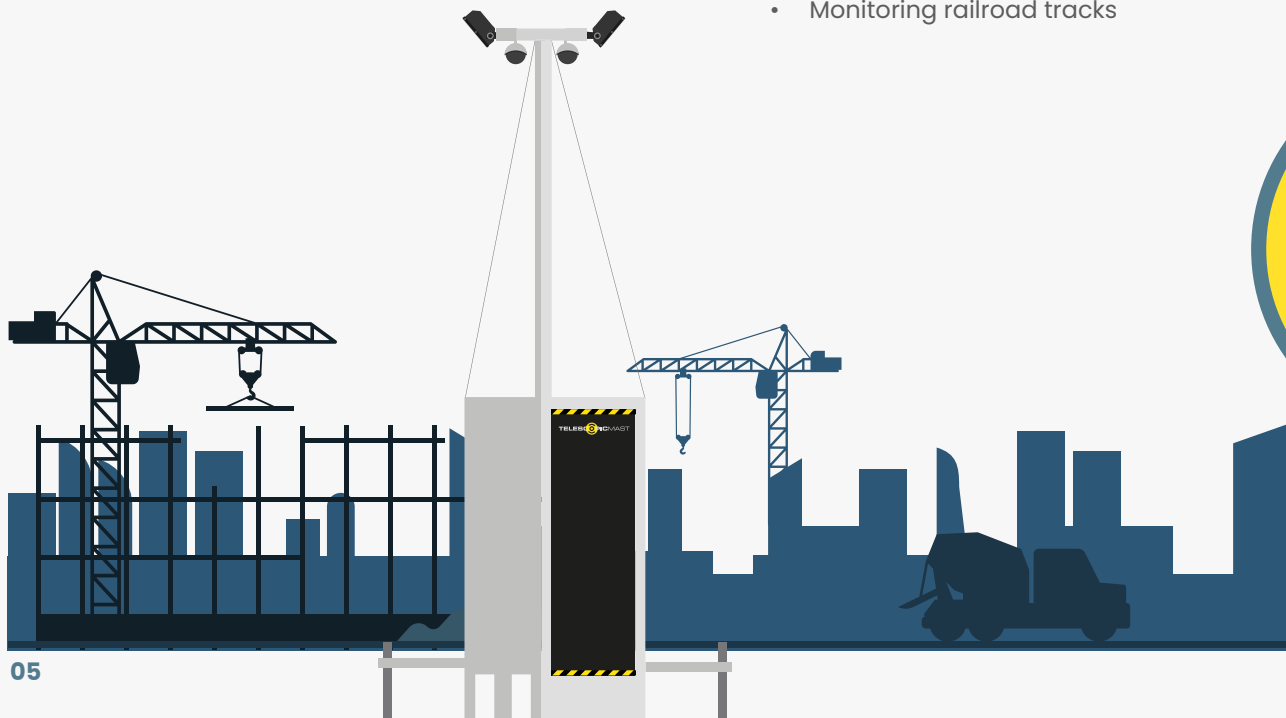

Build your own rapid deployment cctv solution

Create your own CCTV solution

Our Mobile Security Box is designed to be compatible with all the major manufacturers of surveillance equipment. It is built with enough space inside to store all your electronic equipment or power safely inside the vandal resistant box.

This will give you the flexibility to build your own solution, fit for purposes for your market and customer requirements.

The advantage of this is that you are not locked into an expensive pre-built solution. This means that you can save money and time. In addition, you can differentiate your solution with your equipment and branding for your specific market. There are three Mobile Security Boxes in the TelescopicMast range.

Choose the Premium Mast if you require:

- Lockable roof
- Anti roof climb protection
- Heavy-duty mast
- Heavy-duty ground frame

Choose the Basic Plus Mast if you need:

- Lockable roof
- Anti roof climb protection
- Lower cost
- Lighter mast
- Lighter mast ground frame

Choose the Basic Mast if you need:

- Lower cost
- Lighter mast
- Lighter mast ground frame



Add your own devices...



PIR



3G/4G/5G
transmission

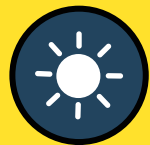

Solar/Fuel
Cells



Cameras



Lighting



Speakers

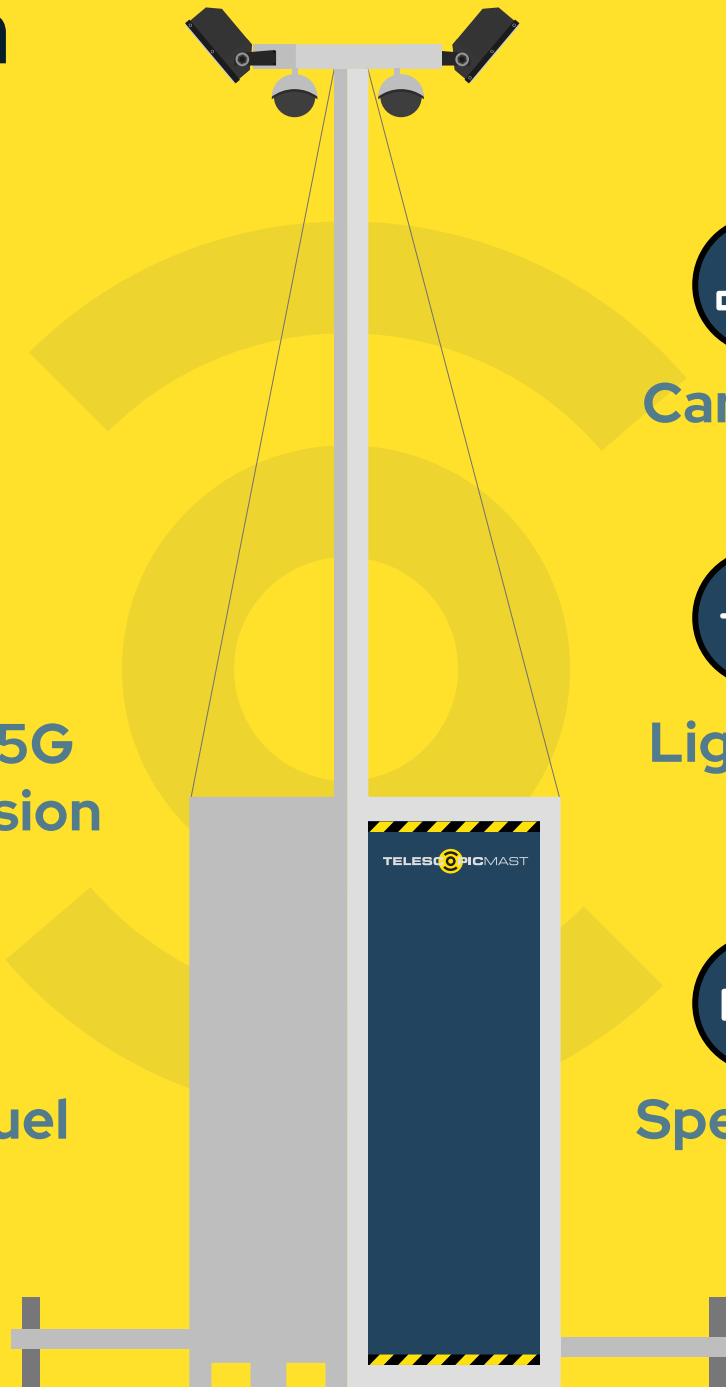

Equipment

You can equip our Telescopicmast with a complete solution of your choice.

1. Choose your cameras:
Fixed, High speed PTZ dome, Thermal, ANPR.
2. Choose your recording device:
Standalone DVR, VMS, NVR.
3. Choose additional equipment:
Detection devices, Audio & Public Address, Lighting.
4. Choose your power source:
Mains power, Battery backup, Fuel cells, Solar power.
5. Brand your box:
Complete your box with custom graphics on each side, promoting your own or your customer's company.

Versatile surveillance at every height

Elevate security with various heights for optimal site protection

The potential of the Mobile Security Box extends to its variable heights – four, six and nine metres. At four metres, it's ideal for close-range surveillance, capturing details that might escape the human eye.

At six metres, it offers a balance between detailed observation and a wider field of view, useful for monitoring large crowds or intricate construction sites.

Achieving a bird's-eye view at nine metres, it provides an unparalleled vantage point, ideal for overseeing extensive infrastructure, identifying potential threats, and overseeing crowd control. Regardless of the chosen height, the tower assures enhanced security and peace of mind.

Upgrade your site's protection today with the Mobile Security Box. Let it be your first line of defence against any potential security risks and safeguard your construction site from start to finish.

"The last five years the Mobile Security Box has been a stable platform for our cameras, even when being used at long distance. TelescopicMast has always been a reliable partner to work with."

"To reduce costs we have looked at several options that can be deployed by a single person. TelescopicMast is clearly top of the market, also from a price /quality perspective."

"We have chosen for TelescopicMast because their tower is robust, secure and easy to transport. It is clearly designed for the rigours of our construction sites and we can easily brand this with our own messaging."



The equipment shown in the picture is for reference only and is not included!

Easy, fast and vandal resistant

Features of the Mobile Security Box

- 1 Built-in extendable mast with a 4 spoke mast top with standard mounts for CCTV cameras or floodlight.
- 2 Steel cables to the masthead which reduce camera vibration that causes false alarms.
- 3 Easy to brand with your personalised message on all four sides of 6,56 x 3,28 ft panels, making this a highly visible way to promote your company.
- 4 Fast to install by only one engineer using the manual winch, reducing installation costs.
- 5 Vandal resistant lockable steel box construction with two lockable top covers protecting your electronic equipment inside.
- 6 Four extendable stabilisers and spirit level to ensure the mast is stable, even in strong winds up to 53 mph.
- 7 Heavy duty forklift slots and mounting points, making it easy for transportation and on-site deployment.



The equipment shown in the picture is for reference only and is not included!

Easy to transport to site

Single & Double Box trailers

Our specially designed trailers for the TelescopicMast Mobile Security Box are available in a single and double axle version. Utilize our lift eyes, forklift, or specially designed trailer to transport and install the Mobile Security Box quickly and easily.

- Heavy support wheel
- Shock absorbers
- Wheel chocks
- Adjustable width forks
- Tie hooks and rails
- Hot dip galvanised chassis

Load,
lift
and drive...



MSB6 – Basic

Value for money

The Mobile Security Box MSB6-Basic provides a fast, cost-effective solution to safeguard unmanned or temporary sites.

Offering a reduction of up to 60% in guarding costs, MSB6-Basic allows rapid detection of intruders, making it ideal for construction sites, vacant properties, infrastructure protection and renewable energy farm security.

The MSB6-Basic takes temporary installations to the next level with its swift deployment and robust protection for electronic gear.

Key features include a six-metre mast with dual camera bracket, vibration-reducing steel cables, and an easy-to-use manual winch. With 100% galvanised steel construction, the MSB6-Basic effectively guards your electronic equipment. It boasts four extendable stabilisers and a spirit level to ensure stability, even in winds up to 53 mph. For easy transportation, forklift slots and mounting points are integrated into the design. Plus, the four-sided exterior can be customised with your messaging, making this a visible and impactful advertising medium.

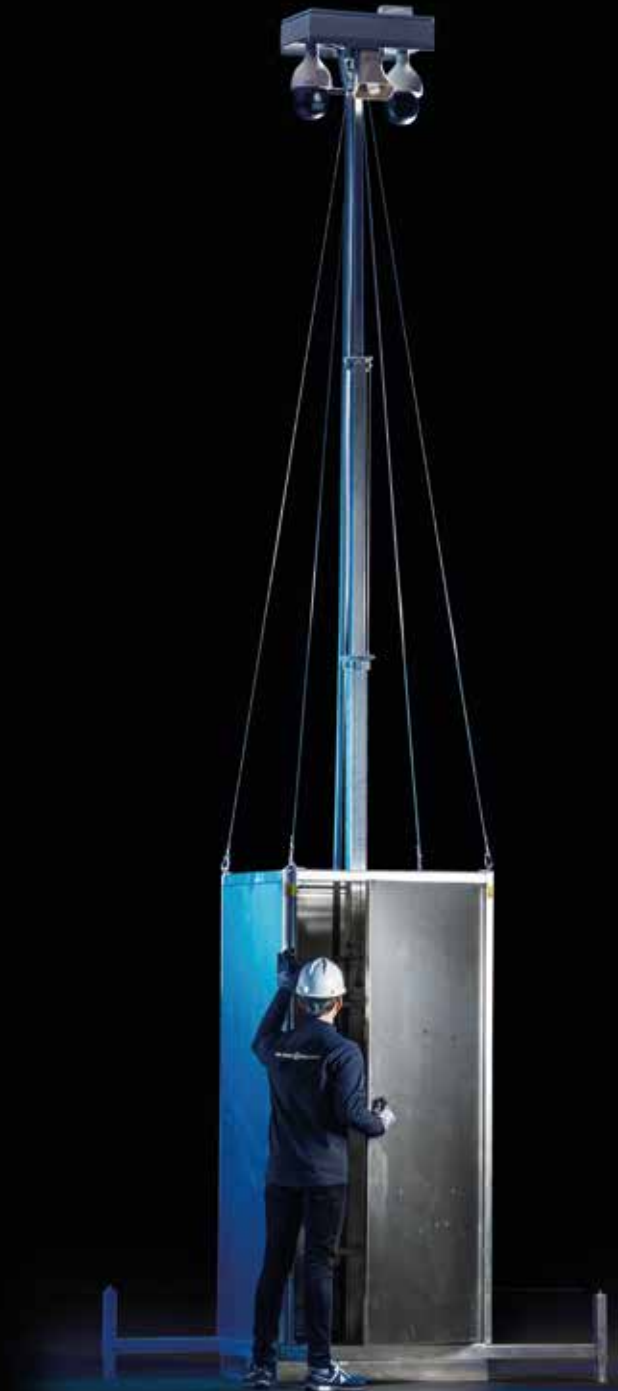

The background image shows a construction site during the day. In the foreground, a white security tower with a camera on top stands on a paved area. A yellow dot is placed on the tower's base, with a thin yellow line extending downwards to a text box. In the middle ground, a blue van with a black cover is parked on the right. The background features a large construction site with a red crane, various materials, and a fence. The sky is bright with some clouds.

Enhancing surveillance, deterrence and rapid response for a safer society

Public security is a vital societal aspect and mobile security towers significantly bolster it. Their strategic deployment in vulnerable areas like shopping districts, train stations, and public gatherings deters potential criminals and assures citizens of their safety. Equipped with advanced surveillance

technology, these towers allow real-time monitoring, ensuring immediate action during emergencies. Investing in these resources and collaborating with security companies enhances community safety and fosters a more secure society. Therefore, prioritising public security and implementing these measures are essential steps towards a safer environment for all.

Specifications and Features

MSB BASIC Specifications

Size LxWxH in cm

100x100x227

Weight in kg

331

Total height with extended mast (in cm)

600

Maximum carrying weight in masttop (in kg)

60

Certifications

CE and ISO9001 CERTIFIED / TÜV

Steel galvanised construction

Steel galvanised mast

Basic 4-part telescopic mast 100/80/60/40mm

MSB BASIC Features

Mobile unit easy to transport to site ✓

Easy to store ✓

Basic ground frame ✓

Easy to install by one engineer ✓

Heavy duty forklift slots, for easy transportation ✓

Lifting eyes, for easy transportation and deployment ✓

Stable Telescopic mast with an automatic safety stop ✓

Four spoke masttop for CCTV cameras or floodlight ✓

Spirit level for easy installation ✓

Two lockable doors to secure equipment ✓

Prepared for additional security lock ✓

Patchbox prepared ✓

4 stabilising cables, reduce vibration and false alarms. ✓

Stabilised by 4 stabilisers up to a wind speed of 85Km/h. ✓

Manual CE approved winch 550 kg ✓

Sides suitable for branding with logo's or messaging ✓

Double cabling in mast (safer for people and equipment) ✓

Sufficient space for installing batteries or fuel cells ✓

Hoisting mast RVS316 stainless steel cables ✓

Hydraulically pressed cable clamp ✓

Manual included ✓

Warning labels ✓

Nylon wheels with bearings ✓



The equipment shown in the picture is for reference only and is not included!

Dimensions and Drawings

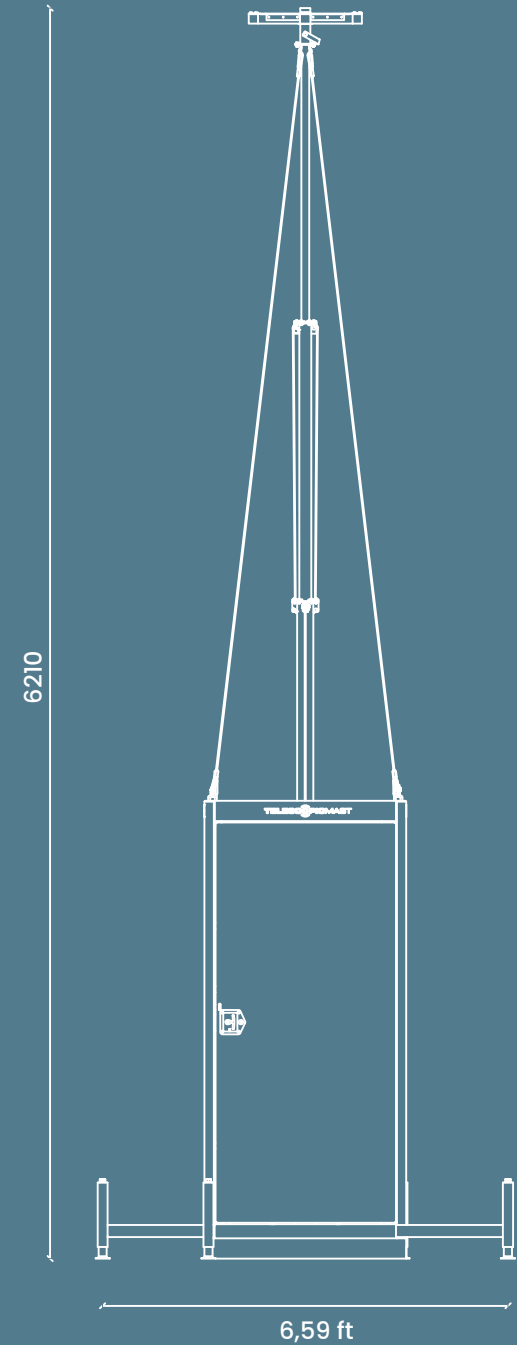
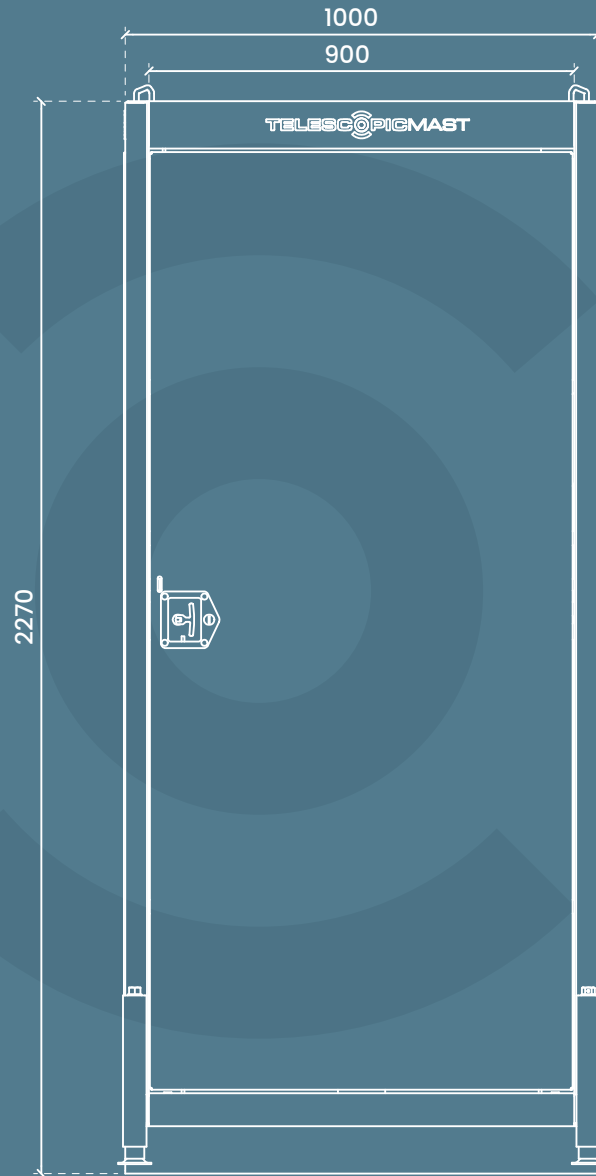
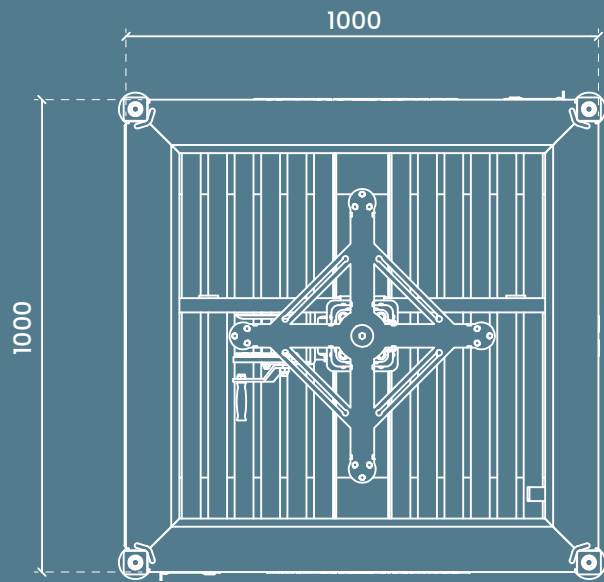

MSB6 – Basic Plus

The Basic with premium features

The Mobile Security Box MSB6-Basic Plus is an invaluable solution for securing unmanned sites and temporary installations, witnessing a surge in demand for rapid deployment CCTV systems. Boasting a cost-saving potential of up to 60% compared to manned guarding, it swiftly detects intruders in diverse settings such as construction sites, vacant properties, and infrastructure protection. It excels in ensuring security for wind and solar farms, car parking lots, stadiums, venues, and public surveillance. A standout feature of the MSB6-Basic Plus is its robust roof climb protection, rendering it highly vandal-resistant.

This is complemented by two lockable top covers that completely encase and shield the electronic equipment within, guaranteeing utmost security.

The MSB6-Basic Plus is easily transportable with forklift slots, quick to install with a manual winch, and visually prominent with customisable branding on all sides. Its 100% galvanised steel construction provides durability and resilience, while the extendable mast, stabilisers, and spirit level ensure stability even in winds of up to 53mph. In essence, the MSB6-Basic Plus stands as a versatile, secure, and cost-effective solution for a wide array of security needs.



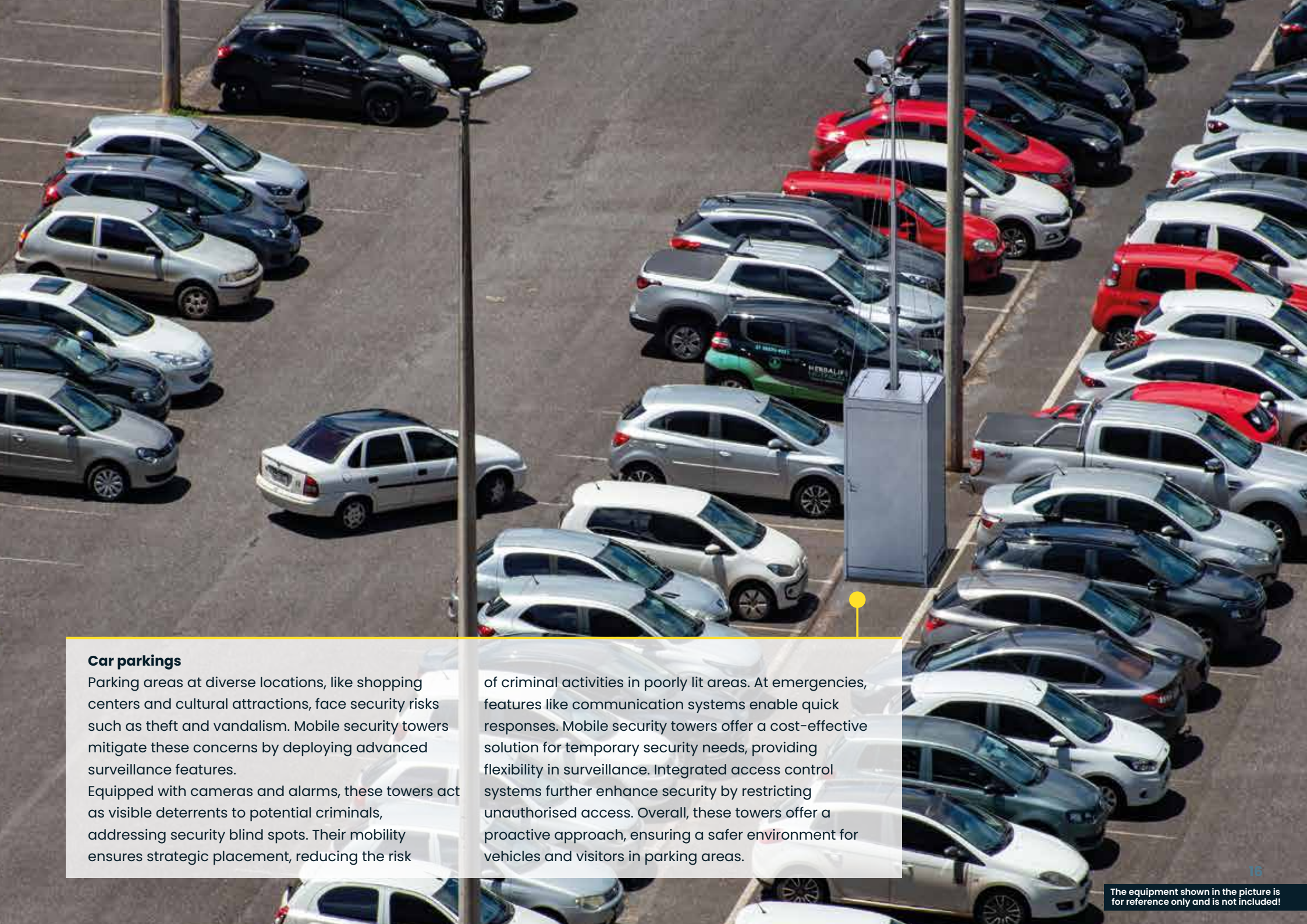

Car parkings

Parking areas at diverse locations, like shopping centers and cultural attractions, face security risks such as theft and vandalism. Mobile security towers mitigate these concerns by deploying advanced surveillance features.

Equipped with cameras and alarms, these towers act as visible deterrents to potential criminals, addressing security blind spots. Their mobility ensures strategic placement, reducing the risk

of criminal activities in poorly lit areas. At emergencies, features like communication systems enable quick responses. Mobile security towers offer a cost-effective solution for temporary security needs, providing flexibility in surveillance. Integrated access control systems further enhance security by restricting unauthorised access. Overall, these towers offer a proactive approach, ensuring a safer environment for vehicles and visitors in parking areas.

Specifications and Features

MSB BASIC PLUS Specifications

Size LxWxH in cm

100x100x227

Weight in kg

350

Total height with extended mast (in cm)

600

Maximum carrying weight in masttop (in kg)

60

Certifications

CE and ISO9001 CERTIFIED / TÜV

Steel galvanised construction

Steel galvanised mast

Basic 4-part telescopic mast 100/80/60/40mm

MSB BASIC PLUS Features

Mobile unit easy to transport to site ✓

Easy to store ✓

Basic ground frame ✓

Easy to install by one engineer ✓

Heavy duty forklift slots, for easy transportation ✓

Lifting eyes, for easy transportation and deployment ✓

Stable Telescopic mast with an automatic safety stop ✓

Four spoke masttop for CCTV cameras or floodlight ✓

Spirit level for easy installation ✓

Two lockable doors to secure equipment ✓

Prepared for additional security lock ✓

Completely closed due to 2 Lockable top covers ✓

Roof climb protection ✓

Patchbox prepared ✓

4 stabilising cables, reduce vibration and false alarms. ✓

Stabilised by 4 stabilisers up to a wind speed of 85Km/h. ✓

Manual CE approved winch 550 kg ✓

Sides suitable for branding with logo's or messaging ✓

Double cabling in mast (safer for people and equipment) ✓

Sufficient space for installing batteries or fuel cells ✓

Hoisting mast RVS316 stainless steel cables ✓

Hydraulically pressed cable clamp ✓

Manual included ✓

Warning labels ✓

Nylon wheels with bearings ✓



The equipment shown in the picture is for reference only and is not included!

Dimensions and Drawings

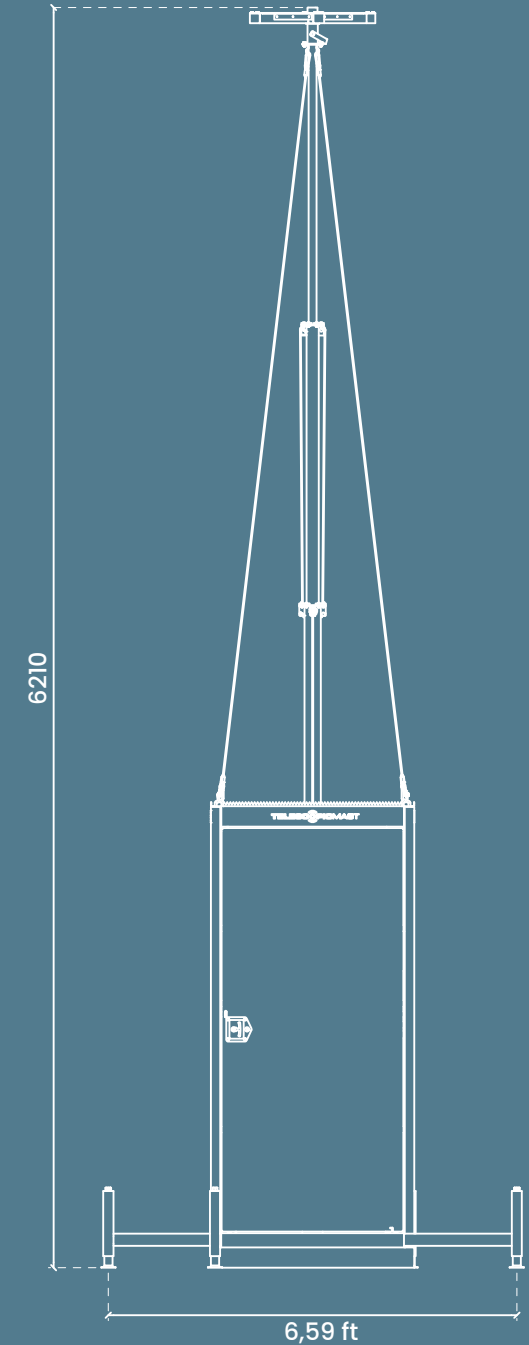
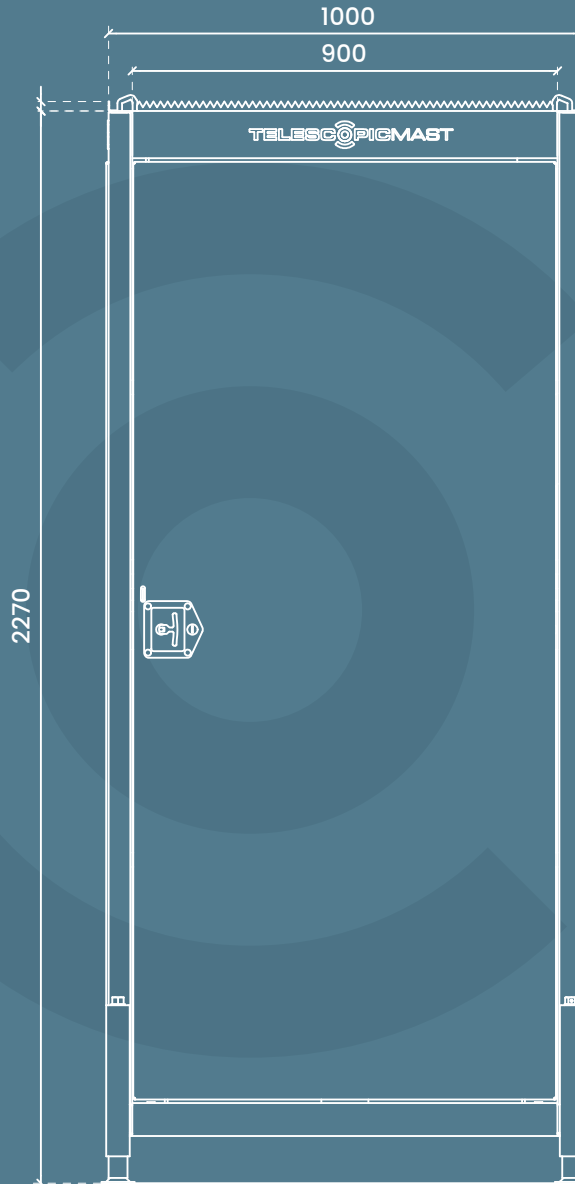
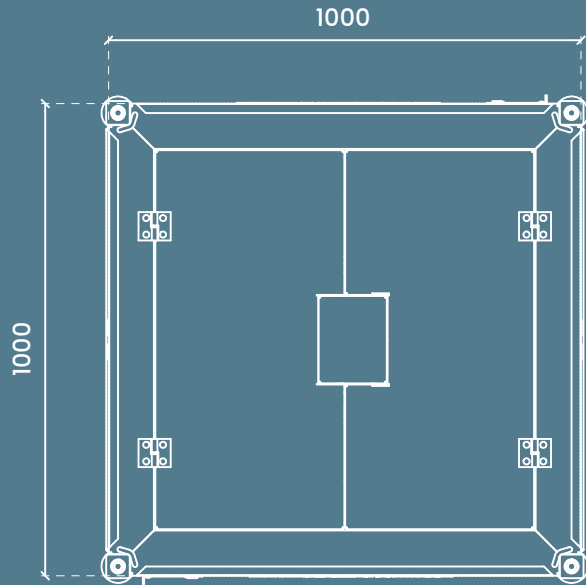

MSB6 – Premium

The Original Mobile Security Box

The Mobile Security Box MSB6–Premium offers robust security solutions for unmanned sites and temporary installations, supporting on-site guarding. Ideal for applications such as construction and industrial site security, protecting vacant properties, and safeguarding infrastructure, it performs in diverse settings like wind and solar farms, car parks, stadiums, venues, and public surveillance.

With a built-in six-metre extendable mast with dual-camera bracket, the MSB6–Premium ensures stability in winds up to 53 mph with four extendable stabilisers.

Key features include a vandal-resistant design with roof climb protection, forklift slots for easy transportation, and lockable top covers securing electronic equipment. Furthermore, the MSB6–Basic Premium stands out with its double lock mechanism and heavy-duty ground frame, ensuring enhanced security.

Quick and cost-effective installation by a single engineer using the manual winch, coupled with 100% galvanised steel construction, makes it a reliable choice for promoting your company with personalised branding on all sides.



Construction sites

Construction sites are susceptible to significant security risks, impacting materials and project investments. Mobile security towers, equipped with CCTV, alarms, and motion sensors, offer an effective solution. Manned by trained personnel and offering movable 24/7 site monitoring, these towers deter theft and vandalism while enhancing overall safety

for workers and visitors. They allow for swift identification and mitigation of potential hazards, providing peace of mind to project managers and investors. Addressing various security concerns, these towers are a recommended investment for construction companies seeking project success and safety.

Specifications and Features

MSB Premium Specifications

Size LxWxH in cm

101x101x234

Weight in kg

416

Total height with extended mast (in cm)

600

Maximum carrying weight in masttop (in kg)

60

Certifications

CE and ISO9001 CERTIFIED / TÜV

Steel galvanised construction

Steel galvanised mast

Premium 4-part telescopic mast 120/100/80/60mm"

MSB Premium Features

Mobile unit easy to transport to site ✓

Easy to store ✓

Heavy duty ground frame ✓

Easy to install by one engineer ✓

Heavy duty forklift slots, for easy transportation ✓

Lifting eyes, for easy transportation and deployment ✓

Stable Telescopic mast with an automatic safety stop ✓

Four spoke masttop for CCTV cameras or floodlight ✓

Spirit level for easy installation ✓

Two lockable doors to secure equipment ✓

Prepared for additional security lock ✓

Completely closed due to 2 Lockable top covers ✓

Roof climb protection ✓

Patchbox prepared ✓

4 stabilising cables, reduce vibration and false alarms. ✓

Stabilised by 4 stabilisers up to a wind speed of 85Km/h. ✓

Manual CE approved winch 550 kg ✓

Sides suitable for branding with logo's or messaging ✓

Double cabling in mast (safer for people and equipment) ✓

Sufficient space for installing batteries or fuel cells ✓

Hoisting mast RVS316 stainless steel cables ✓

Hydraulically pressed cable clamp ✓

Manual included ✓

Warning labels

Nylon wheels with bearings

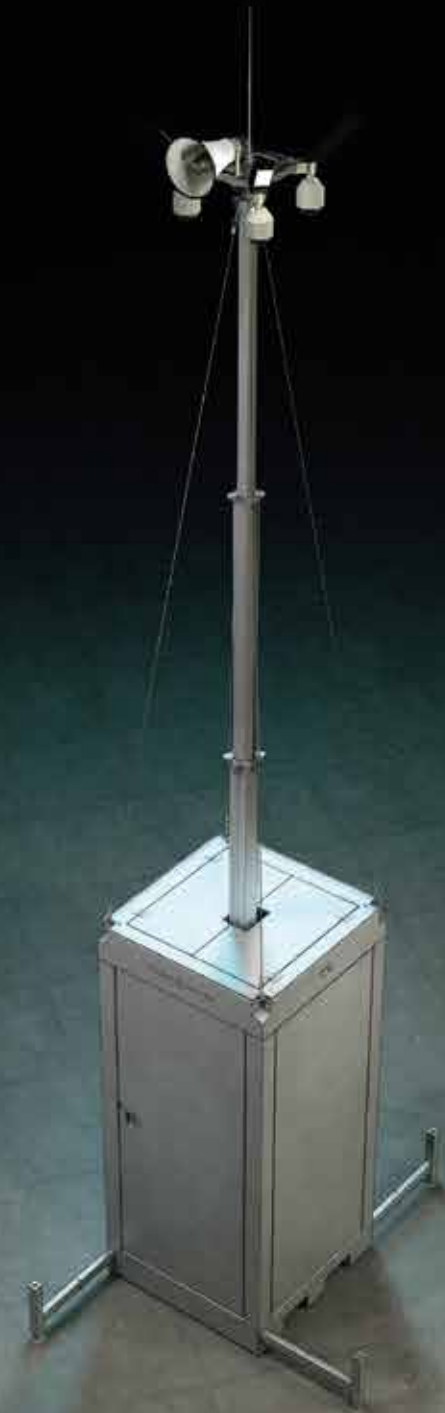

The equipment shown in the picture is for reference only and is not included!

Dimensions and Drawings

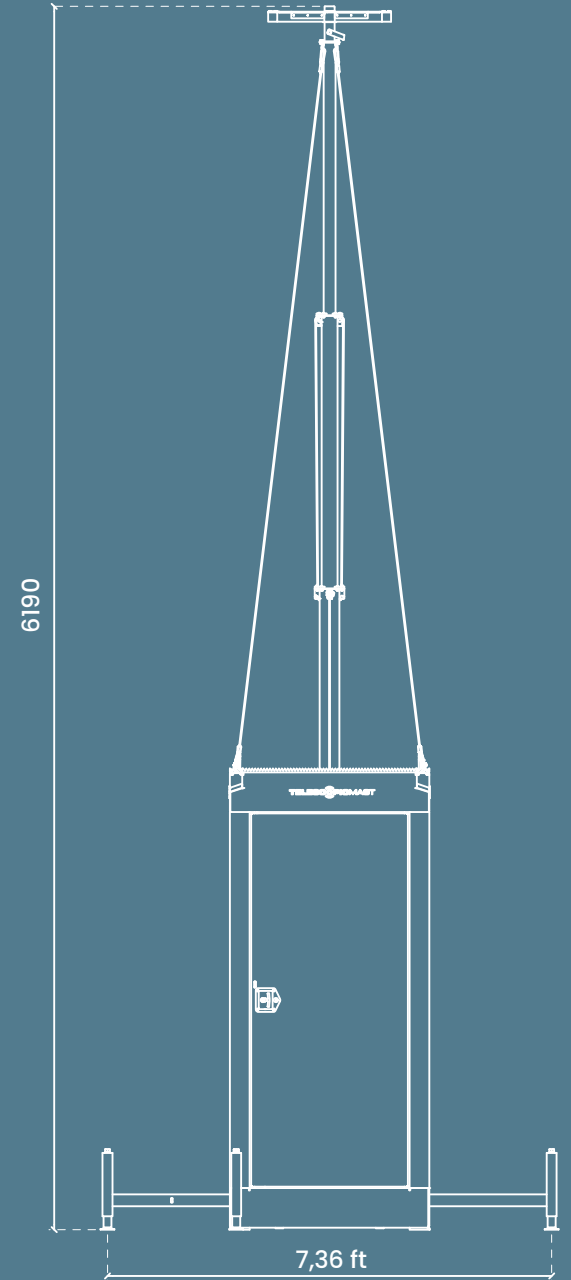
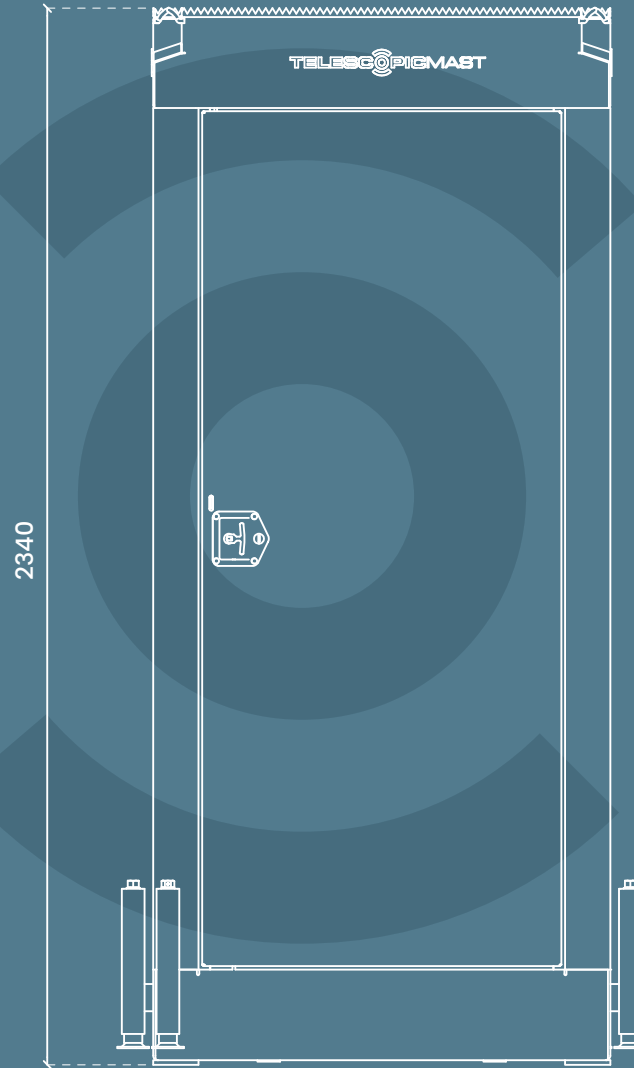
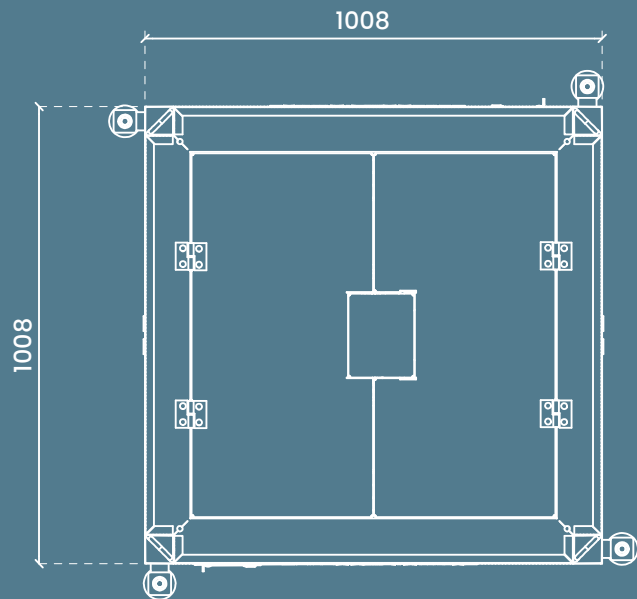

MSB - Premium XL

The Extra Large Mobile Security Box

The Mobile Security Box MSB-Premium XL shares the specifications found in the MSB6-Premium and is specifically tailored for safeguarding unmanned sites, temporary installations and supporting on-site guarding. With the additional feature of a taller 9-metre mast making it ideal for various applications such as securing construction sites, industrial facilities, vacant properties, infrastructure, wind and solar farms, car parking, stadiums, venues and public surveillance.

Key features of the MSB-Premium XL include steel cables to the mast head, mitigating camera vibrations for accurate alarm detection.

Its highly visible surfaces offer easy branding opportunities for personalised company messages. The unit boasts a swift, one-engineer installation using a manual winch, reducing overall installation costs.

Crafted from 100% galvanised steel, it ensures robust protection for internal electronic components.

The mast's total height extends to 9 metres, providing an advantageous three-metre increase compared to the MSB6 models. This heightened elevation enhances the CCTV cameras' viewing angle, augmenting overall surveillance effectiveness.

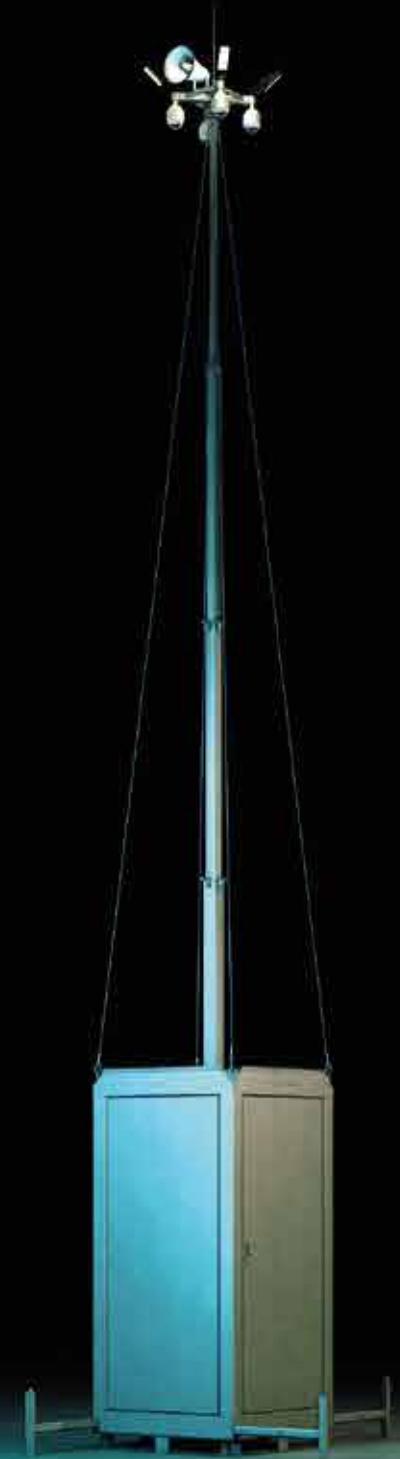



Infrastructure works

Infrastructure works often face significant security risks, necessitating effective measures to ensure safety. Mobile security towers serve as a crucial solution, offering a cost-efficient way to enhance security. They eliminate the need for on-site security officers and provide adaptability to shifting security threats and safety risks. These towers can protect remote sites and improve safety in transport applications promoting a safe environment for workers. Therefore, consider incorporating mobile security towers in your next infrastructure project, particularly for road works. They provide a beneficial, safe and remotely accessible solution to manage safety concerns.

Specifications and Features

MSB - Premium XL Specifications

Size LxWxH in cm

114x114x250

Weight in kg

502

Total height with extended mast (in cm)

900

Maximum carrying weight in masttop (in kg)

60

Certifications

CE and ISO9001 CERTIFIED / TÜV

Steel galvanised construction

Steel galvanised mast

Premium 5-part telescopic mast

120/100/80/60/40mm

MSB - Premium XL Features

Mobile unit easy to transport to site ✓

Easy to store ✓

Basic extended ground frame ✓

Easy to install by one engineer ✓

Heavy duty forklift slots on 4 sides, for easy transportation ✓

Lifting eyes, for easy transportation and deployment ✓

Stable Telescopic mast with an automatic safety stop ✓

Four spoke masttop for CCTV cameras or floodlight ✓

Spirit level for easy installation ✓

Two lockable doors to secure equipment ✓

Prepared for additional security lock ✓

Patchbox prepared ✓

4 stabilising cables, reduce vibration and false alarms. ✓

Stabilised by 4 stabilisers up to a wind speed of 85Km/h. ✓

Manual CE approved winch 850 kg ✓

Sides suitable for branding with logo's or messaging ✓

Double cabling in mast (safer for people and equipment) ✓

Sufficient space for installing batteries or fuel cells ✓

Hoisting mast RVS316 stainless steel cables ✓

Hydraulically pressed cable clamp ✓

Manual included ✓

Warning labels ✓

Nylon wheels with bearings ✓



Dimensions and Drawings

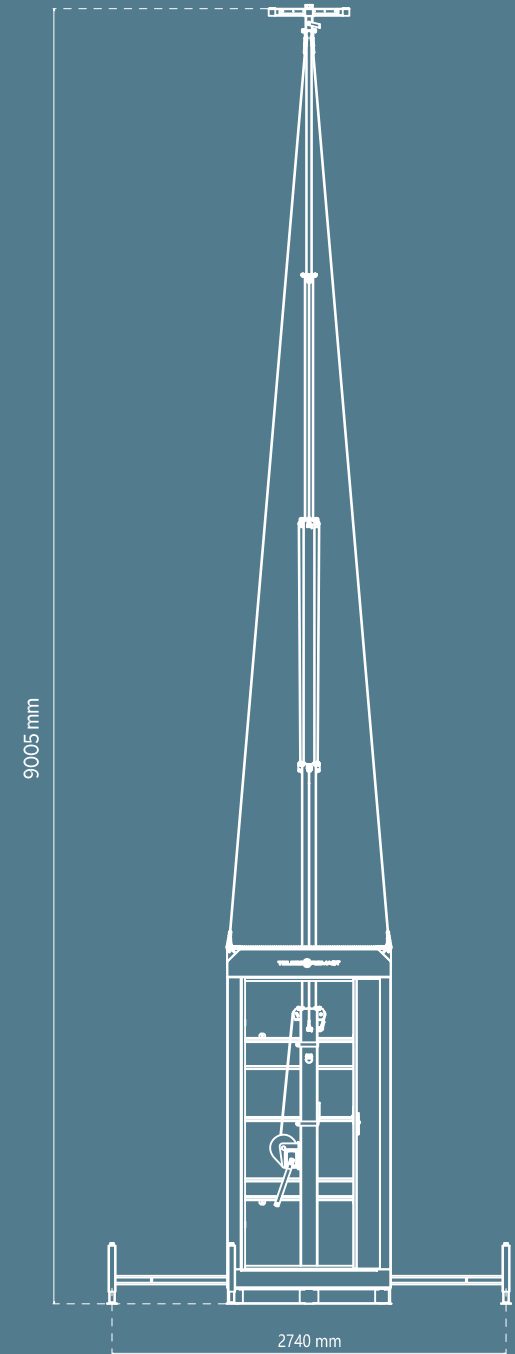
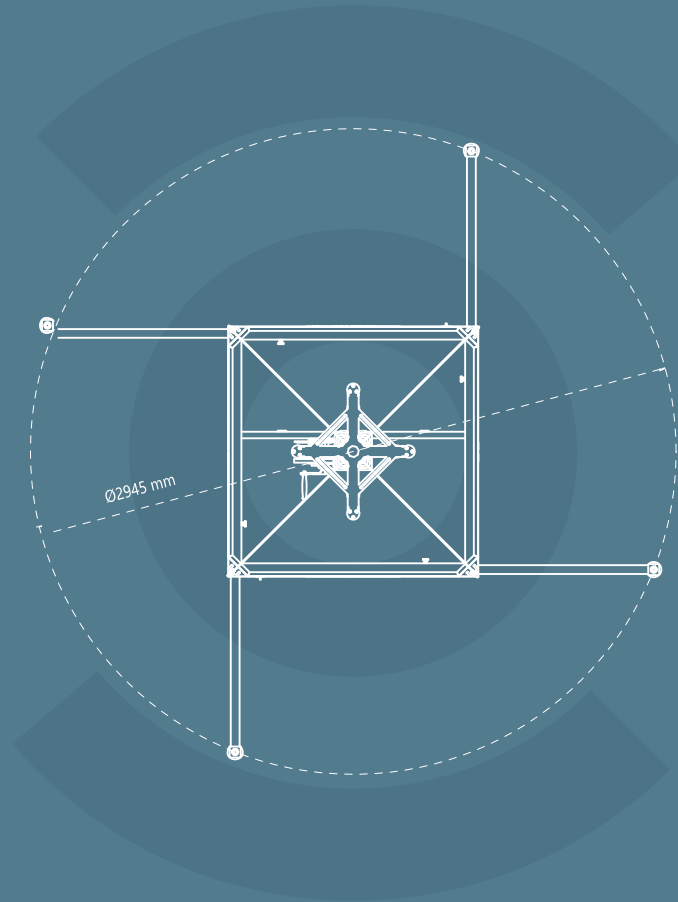
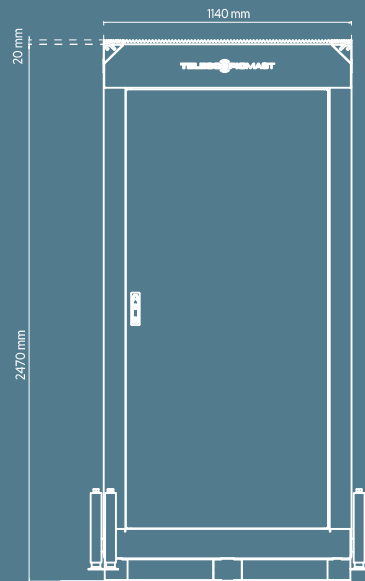
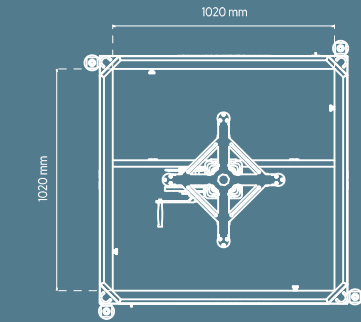

MSB - Compact

The Compact Mobile Security Box

The MSB-Compact is a mobile security cabinet that is smaller than its larger brothers. However, it still offers many of the same features, including faster deployment and a compact size that makes it suitable for indoor use. In addition, the MSB-Compact is particularly suitable for locations where space is limited, such as busy urban areas or alongside railway tracks.

It features a 13.3 ft mast height that enables you to closely monitor all situations and is suitable for the most common applications in securing terrain, objects and people.

The MSB-Compact is also easy to handle, with a completely closed housing and an IP66 patch cabinet that makes installations quick and easy.

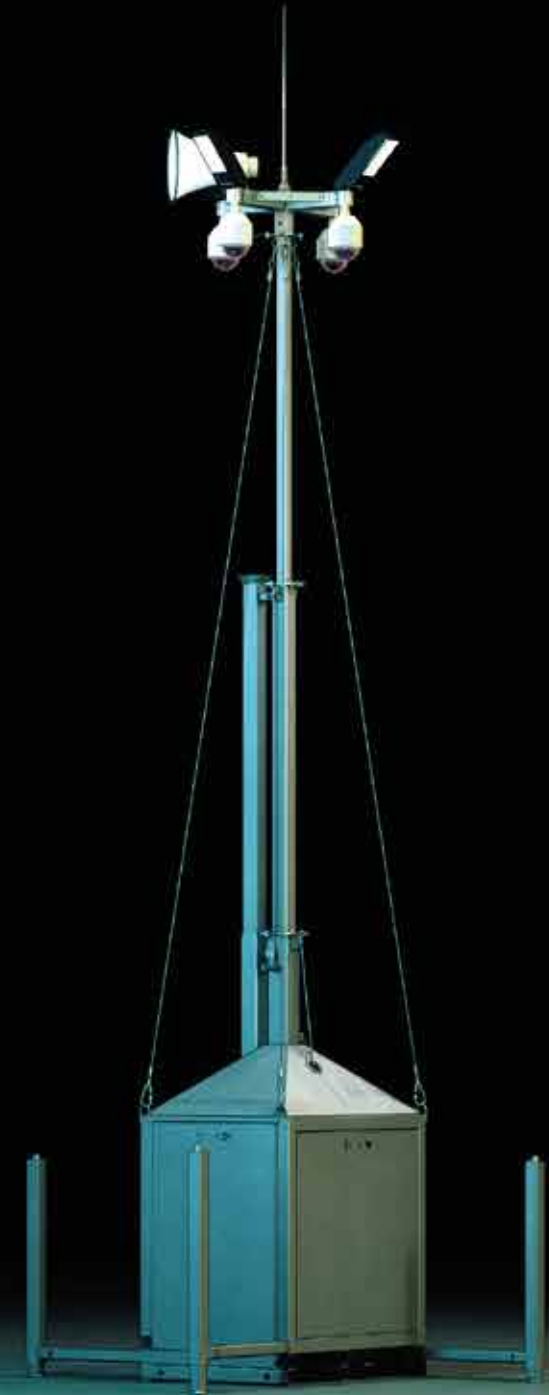

Solar Parks

Solar parks, with their high-value equipment including copper in solar panels, face significant security risks such as vandalism and sabotage. These threats can cause substantial financial losses and reputational damage. Mobile security towers, equipped with advanced surveillance technology can mitigate these risks by providing real-time alerts to any unauthorised activities. Their presence also serves as a powerful deterrent to potential offenders. Therefore, the inclusion of mobile security towers is a proactive strategy to safeguard substantial investments made in solar parks, ensuring them long-term success and the sustainability of these valuable renewable energy sources.



Specifications and Features

MSB COMPACT Specifications

Size LxWxH in cm

62x80x180

Weight in kg

190

Total height with extended mast (in cm)

405

Maximum carrying weight in masttop (in kg)

60

Certifications

CE CERTIFIED / TÜV pending

Steel galvanised construction

Steel galvanised mast

Basic 3-part telescopic mast 80/60/40mm

MSB COMPACT Features

Mobile compact unit easy to transport to site	✓
Easy to store	✓
Basic ground frame	✓
Easy to install by one engineer	✓
Forklift slots for easy transportation	✓
Lifting eyes, for easy transportation and deployment	✓
Stable Telescopic mast with an automatic safety stop	✓
Four spoke masttop for CCTV cameras or floodlight	✓
Spirit level for easy installation	✓
Cylinder lock	✓
Prepared for additional security lock	✓
Fully Lockable cabinet	✓
Vandal resistant cable conduit	✓
Roof climb protection	✓
Patchbox / IP66 box installed	✓
4 stabilising cables, reducing vibration and false alarms	✓
Stabilised by 4 stabilisers up to a wind speed of 85Km/h.	✓
Manual CE approved winch 550 kg	✓
4 Sides suitable for branding with logo's or messaging	✓
Double cabling in mast (safer for people and equipment)	✓
Sufficient space for installing batteries or fuel cells	✓
Hoisting mast RVS316 stainless steel cables	✓
Hydraulically pressed cable clamp	✓
Manual included	✓
Warning labels	✓
Nylon wheels with bearings	✓



The equipment shown in the picture is for reference only and is not included!

Dimensions and Drawings

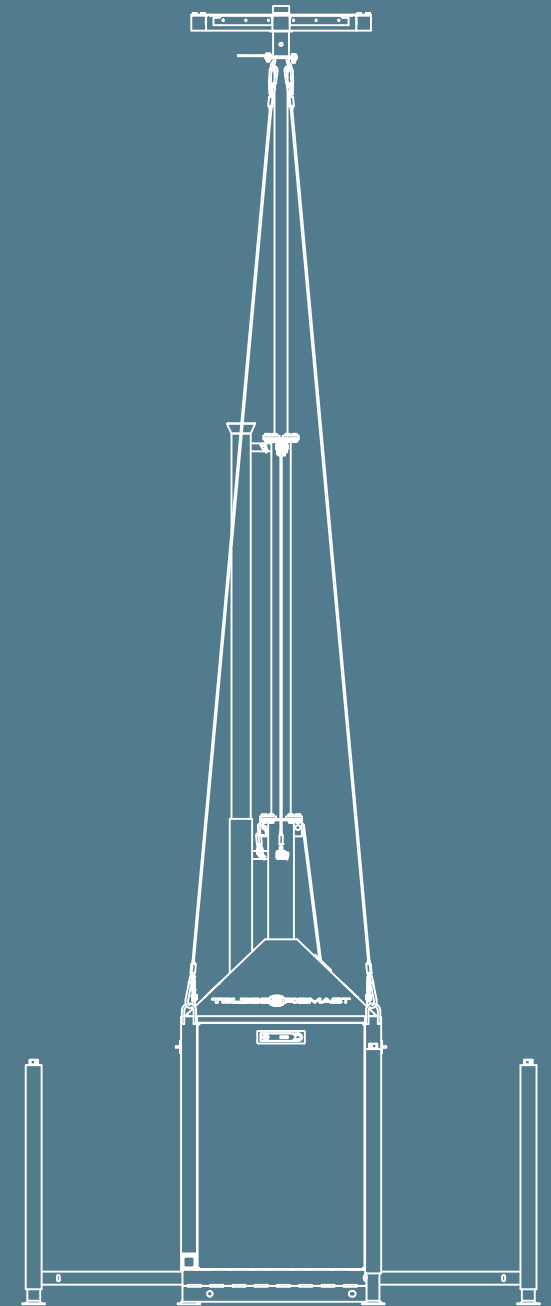
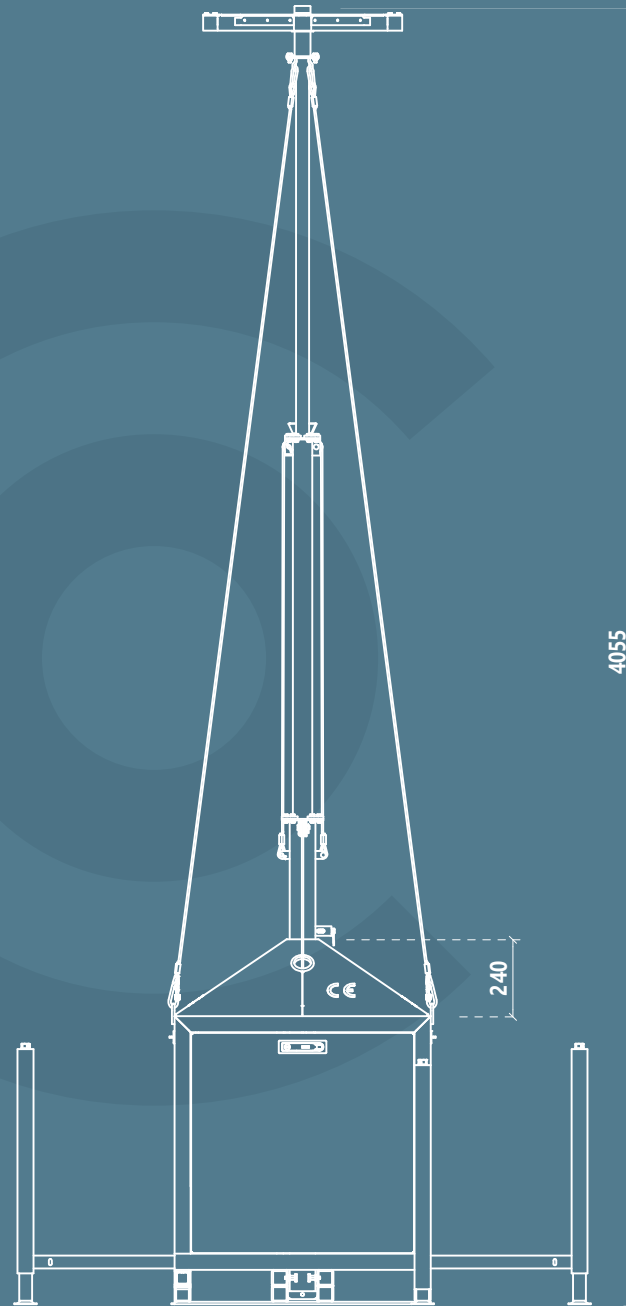
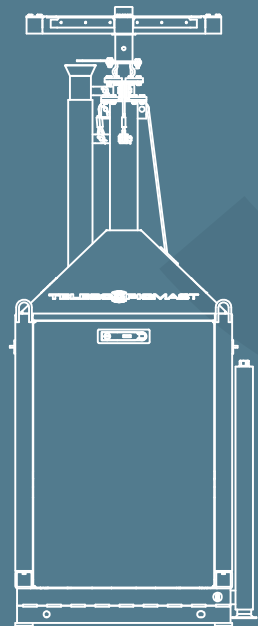
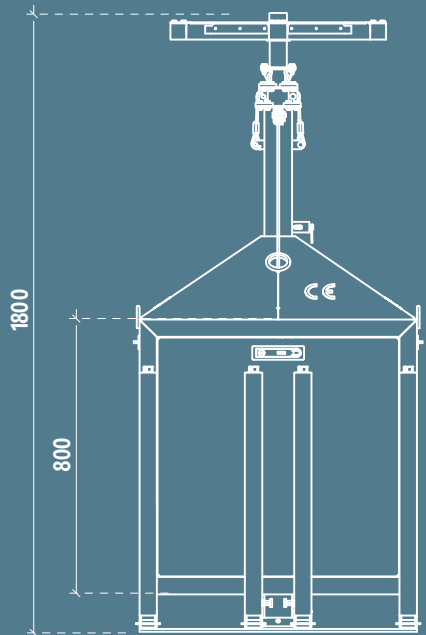
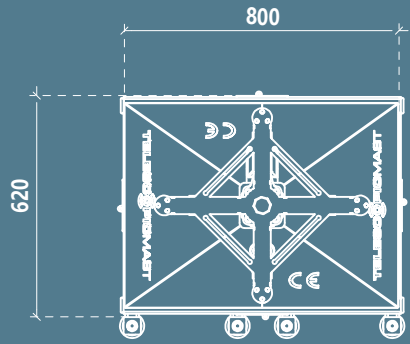

MSB – Roadbox

A Flexible Highway Hero

The idea for the MSB-Compact security cabinet came from our customers. We know that many of our customers use one of our standard trailers to transport our larger cabinets to their desired locations. For this purpose, we have designed a special MSB Minitrailer for the MSB-Compact. Purchased together makes the MSB-Roadbox!

This MSB-Roadbox combination, is designed to give you the flexibility and rapid deploy ability of the MSB-Compact. Of course, you can still use the Minitrailer to independently transport your fleet of MSB-Compacts to various locations or you can deploy the Compact mast on site whilst on the trailer as a stable standalone mast.



Embrace the power of the Roadbox and establish your own fleet

You can conveniently leave the Roadbox on location as long as necessary and when you need to redeploy simply retract the legs and attach it to your vehicle. This makes the Roadbox particularly suitable for solving short-term security issues or in situations where the installation needs to be moved regularly.

For example in deployment during emergencies, at events, or temporary roadworks, where the area being protected moves over time. This way, the installation on location becomes much more flexible which saves a lot of installation time, reduces labour costs and speeds up re-deployment times.

This combined mast and trailer solution helps throughout the deployment process and offers greater flexibility on site.



Specifications and Features

MSB ROADBOX Specifications

Size transport mode LxWxH in cm

240x139x228

Size operational mode LxWxH in cm

188x140x228 (drawbar excluded)

Weight in kg

365

Total height with extended mast (in cm)

452

Maximum carrying weight in masttop (in kg)

60

Certifications

CE CERTIFIED / TÜV pending

Steel galvanised construction

Steel galvanised mast

Basic 3-part telescopic mast 80/60/40mm

MSB ROADBOX Features

Mobile trailer, unit easy to transport to site ✓

For transport or as a fixed mobile CCTV security solution ✓

Easy to store ✓

Easy to install by one engineer ✓

Heavy duty forklift slots, for easy transportation ✓

Lifting eyes, for easy transportation and deployment ✓

Stable Telescopic mast with an automatic safety stop ✓

Four spoke masttop for CCTV cameras or floodlight ✓

Spirit level for easy installation ✓

Cylinder lock ✓

Prepared for additional security lock ✓

Fully Lockable cabinet ✓

Vandal resistant cable conduit ✓

Roof climb protection ✓

Patchbox / IP66 box installed ✓

4 stabilising cables, reducing vibration and false alarms ✓

Stabilised by 4 stabilisers up to a wind speed of 85Km/h. ✓

Manual CE approved winch 550 kg ✓

2 Sides suitable for branding with logo's or messaging ✓

Double cabling in mast (safer for people and equipment) ✓

Sufficient space for installing batteries or fuel cells ✓

Hoisting mast RVS316 stainless steel cables ✓

Hydraulically pressed cable clamp ✓

Manual included ✓

Warning labels ✓

Nylon wheels with bearings ✓



Dimensions and Drawings

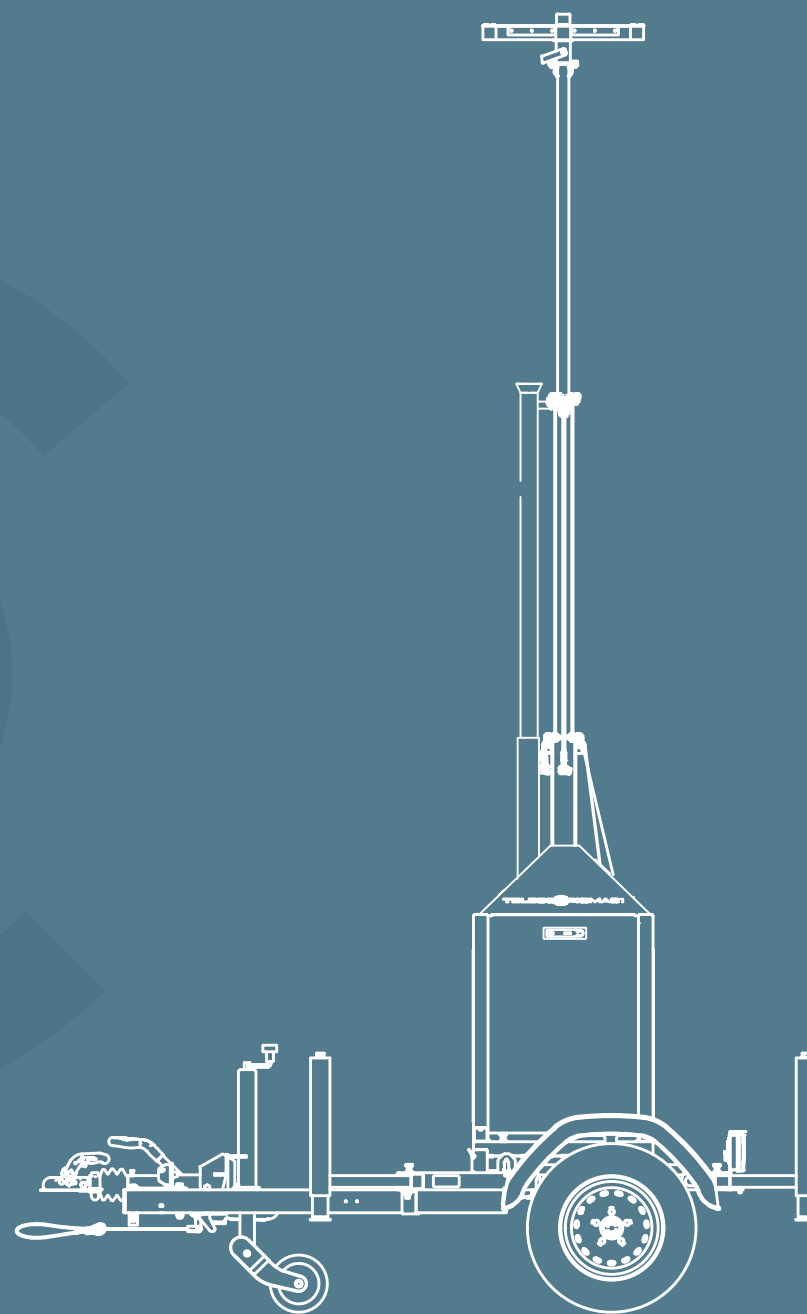
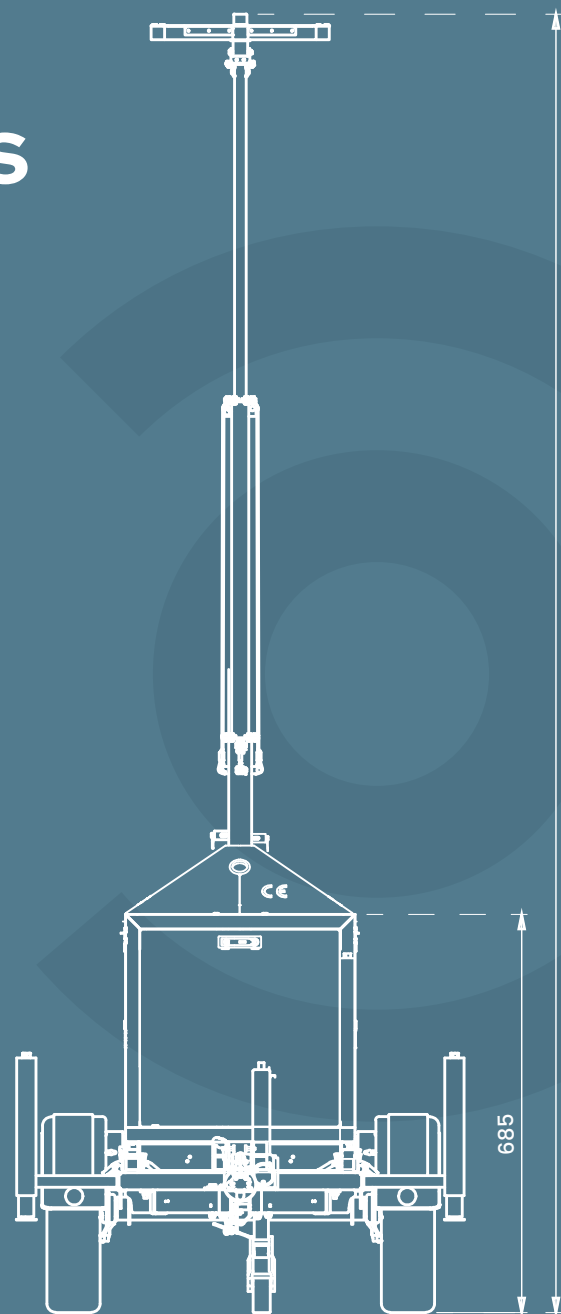
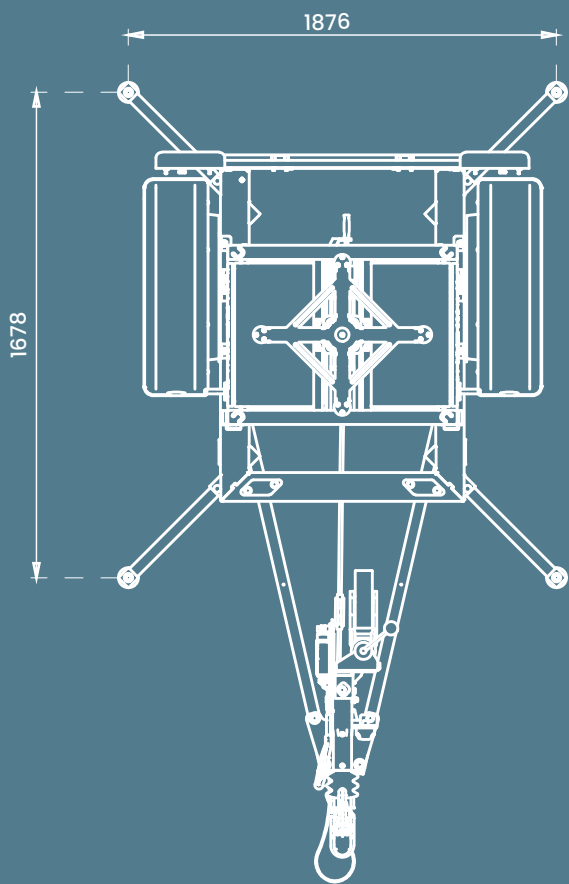

What meets your requirements?

Key features

Our expert team is ready to assist you in determining which security tower best suits your specific requirements and operational environment. We are more than willing to guide you in selecting the ideal security tower for your needs.

MSB6 - Basic



- CE certified/ TÜV approved
- Steel galvanised construction
- Standard 4-part steel telescopic mast
- Boxsize: 100x100x227cm
- Weight: 331 kg
- Maximum carrying weight on masttop: 60kg
- Height with extended mast: 600cm

MSB6 - Basic Plus

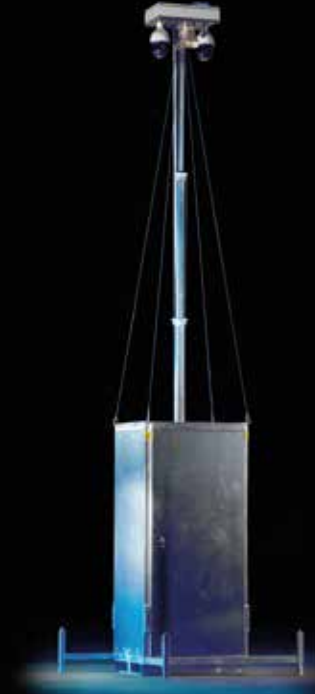

- CE certified
- Steel galvanised construction
- Standard 4-part steel telescopic mast
- Boxsize: 100x100x227cm
- Weight: 350 kg
- Maximum carrying weight on masttop: 60kg
- Height with extended mast: 600cm

MSB6 - Premium



- CE certified/ TÜV approved
- Heavy duty Steel galvanised construction
- Heavy duty 4-part steel telescopic mast
- Boxsize: 101x101x234cm
- Weight: 416 kg
- Maximum carrying weight on masttop: 60kg
- Height with extended mast: 600cm

MSB - Compact



- CE certified/ TÜV approved
- Steel galvanised construction
- Standard 3-part steel telescopic mast
- Boxsize: 62x80x180cm
- Weight: 190 kg
- Maximum carrying weight on masttop: 60kg
- Height with extended mast: 405cm

MSB - Premium XL

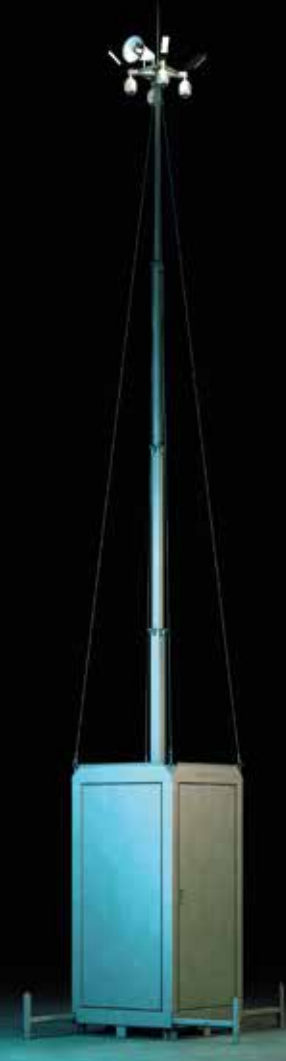

- CE certified/ TÜV approved
- Heavy duty Steel galvanised construction
- Heavy duty 5-part steel telescopic mast
- Boxsize: 114x114x250cm
- Weight: 502 kg
- Maximum carrying weight on masttop: 60kg
- Height with extended mast: 900cm

Select your preferred tower

Features Comparison

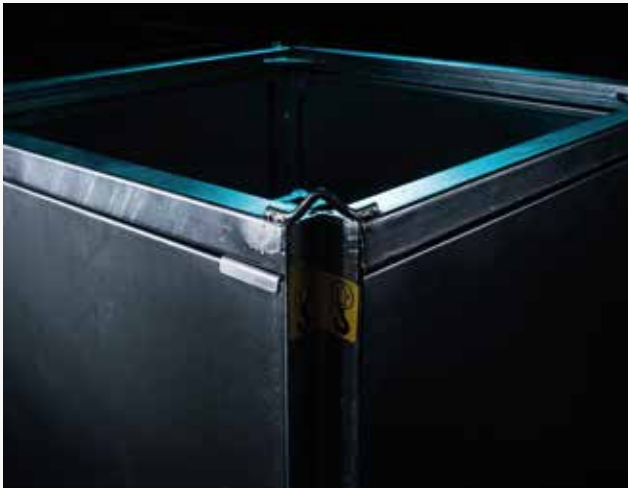

MSB Basic



MSB Basic Plus



MSB Premium

Feature	MSB6 - Basic	MSB6 - Basic Plus	MSB6 - Premium	MSB - Compact	MSB - Premium XL
Mobile unit easy to transport to site	✓	✓	✓	✓	✓
Easy to store	✓	✓	✓	✓	✓
Basic ground frame	✓	✓		✓	
Heavy duty ground frame			✓		✓
Easy to install by one engineer	✓	✓	✓	✓	✓
Heavy duty forklift slots, for easy transportation	✓	✓	✓	✓	✓
Forklift slots on 4 sides					✓
Lifting eyes, for easy transportation and deployment	✓	✓	✓	✓	✓
Stable Telescopic mast with an automatic safety stop	✓	✓	✓	✓	✓
Four spoke masttop for CCTV cameras or floodlight	✓	✓	✓	✓	✓
Spirit level for easy installation	✓	✓	✓	✓	✓
Two lockable doors to secure equipment	✓	✓	✓		✓
Four lockable panels to secure equipment				✓	
3 point cylinder lock	✓	✓	✓	✓	✓
Prepared for additional security lock	✓	✓	✓	✓	✓
Completely closed (due to 2 Lockable top covers)		✓	✓	✓	✓
Vandalism resistant		✓	✓		✓
Vandal resistant cable conduit				✓	
Roof climb protection		✓	✓	✓	✓
Patchbox prepared	✓	✓	✓		✓
IP66 patchbox installed				✓	
4 stabilising cables, reduce vibration and false alarms	✓	✓	✓	✓	✓
Stabilised by 4 stabilisers up to a wind speed of 85Km/h	✓	✓	✓	✓	✓
Manual CE approved winch	✓	✓	✓	✓	✓
Sides suitable for branding with logo's or messaging	✓	✓	✓	✓	✓
Double cabling in mast (safer for people and equipment)	✓	✓	✓	✓	✓
Sufficient space for installing batteries or fuel cells	✓	✓	✓	✓	✓
Hoisting mast RVS316 stainless steel cables	✓	✓	✓	✓	✓
Hydraulically pressed cable clamp	✓	✓	✓	✓	✓
Manual included	✓	✓	✓	✓	✓
Warning labels	✓	✓	✓	✓	✓
Nylon wheels with bearings	✓	✓	✓	✓	✓

Easy to transport to site

Mobile Security Box Trailers

Efficiently transport Mobile Security Boxes with our specially designed trailers, eliminating the necessity for flatbed trucks. Load, lift, and drive with ease, ensuring a swift and straightforward journey to your site. This innovative solution enables the safe transportation of masts without the need for a flatbed truck, allowing for easy unloading and precise positioning even in challenging terrains.

Designed for single-person operation, our trailers simplify mast installation. Navigate limited space and access points effortlessly, manoeuvring masts into position with convenience. No specialised driving licence is required, ensuring safe transport on both UK and European roads. Streamline your mast logistics for quick and secure deployments.

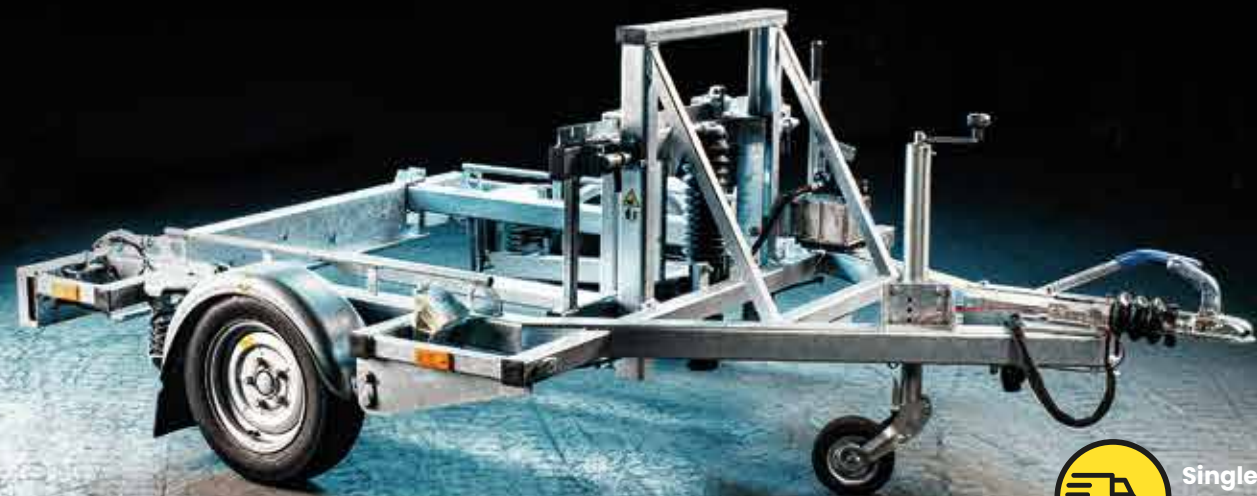
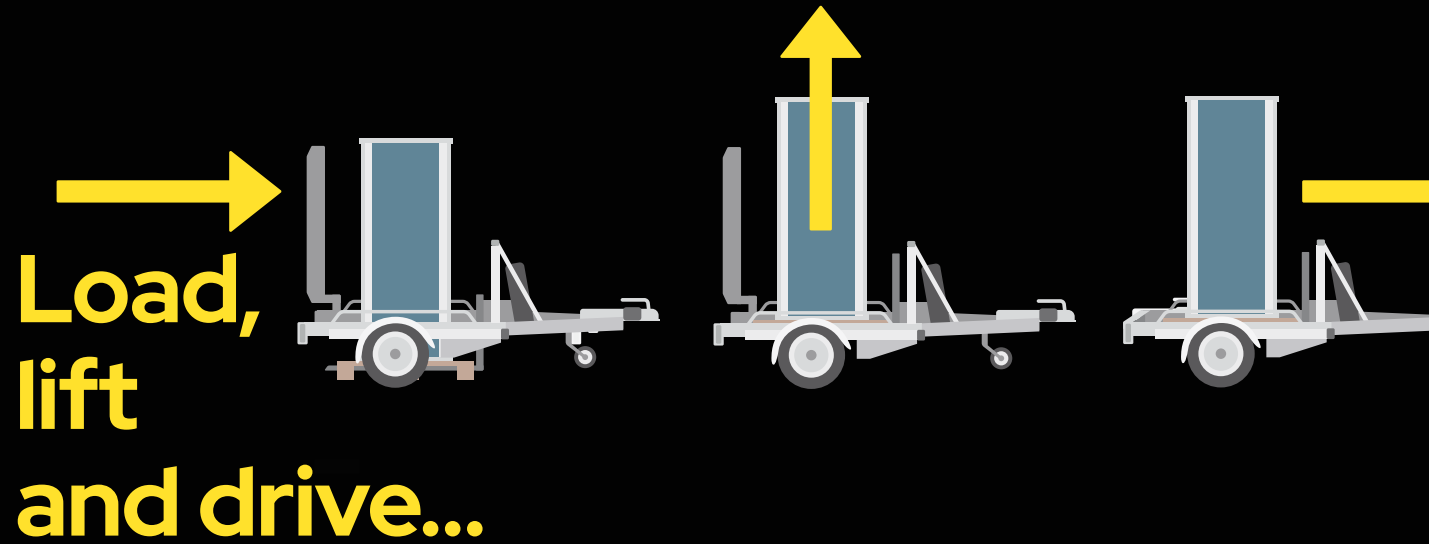

Single Box Trailer:
model TMT-1300

Mobile Security Box Trailers

TMT-750 / 1300 / 2500



Minitrailer for boxmodel Compact:
model TMT-750



Double Box Trailer:
model TMT-2500

TMT-750

TMT-1300

TMT-2500

Maximum permissible weight:

750kg	1300kg	2500kg
-------	--------	--------

Own weight:

170kg	375kg	650kg
-------	-------	-------

Load capacity:

750kg	925kg	1800kg
-------	-------	--------

Loading space dimensions (LxW):

62x80cm	125x125cm	250x125cm
---------	-----------	-----------

Axle:

Single axle 750 kg	Single axle 1300 kg	Twin axle 2500 kg
--------------------	---------------------	-------------------

Braked axle(s)

Yes	Yes	Yes
-----	-----	-----

Lifting Mechanism:

-	Hydraulic	Electric - hydraulic
---	-----------	----------------------

Standard equipped with:

- | | | |
|--|---|---|
| <ul style="list-style-type: none"> • Heavy support wheel • Shock absorbers • Hot dip galvanised chassis | <ul style="list-style-type: none"> • Heavy support wheel • Shock absorbers • Wheel chocks • Adjustable forks (width) • Tie hooks and rails • Hot dip galvanised chassis | <ul style="list-style-type: none"> • Heavy support wheel • Shock absorbers • Wheel chocks • Adjustable forks (width) • Tie hooks and rails • Hot dip galvanised chassis |
|--|---|---|

Create your easy to install solution

Mobile Security Box Solar Equipped



The interior of the Mobile Security Box is designed to accommodate a patch cabinet for electronic equipment storage. It also offers ample space to house power sources and batteries, ensuring the security tower's autonomous operation. On the exterior, the tower is equipped for easy attachment of solar panels, enhancing its sustainability and energy efficiency. This comprehensive design allows for seamless integration of technology, offering a self-sufficient and environmentally conscious solution for mobile security needs.

With a focus on both internal functionality and external adaptability, this Mobile Security Box provides a versatile and efficient platform for safeguarding assets in various settings.



Self-sufficient solutions with integrated technology

Efficiently store electronics, power sources and batteries

The MSB-Compact and MSB-Roadbox, excel in versatility with an interior design tailored for optimal functionality. Housing a dedicated patch cabinet for electronic equipment storage, these security towers prioritise organised and efficient management. Beyond this, the interior offers ample space for power sources and batteries, ensuring uninterrupted and autonomous operation.

Externally, the towers are equipped for seamless attachment of solar panels, a feature that enhances their sustainability and energy efficiency. This forward-thinking design allows for the harnessing of solar energy, aligning with an environmentally conscious approach.





The design of the Compact and Roadbox seamlessly integrates cutting-edge technology, presenting a self-sufficient solution for diverse mobile security needs. The focus on internal functionality and external adaptability positions these towers as efficient platforms for safeguarding assets in various settings.

By addressing the needs of electronic equipment storage and power autonomy these towers exemplify a versatile and environmentally conscious approach to mobile security. The Compact and Roadbox redefine the landscape of mobile security solutions, setting a new standard for efficiency, adaptability, and environmental responsibility.



Brand your Mobile Security Box

Create a Unique Identity

Branding mobile security boxes on four sides and enhances visibility, acting as mobile advertising in high-traffic areas. This not only promotes brand recognition but also conveys trust and credibility in secure environments. In emergency situations, strategically positioned security boxes contribute to overall security preparedness.

Branded boxes serve as a valuable tool for increased brand recall, making them a multifaceted asset as they serve primarily as security towers with the added benefit of brand awareness for the company deploying them.

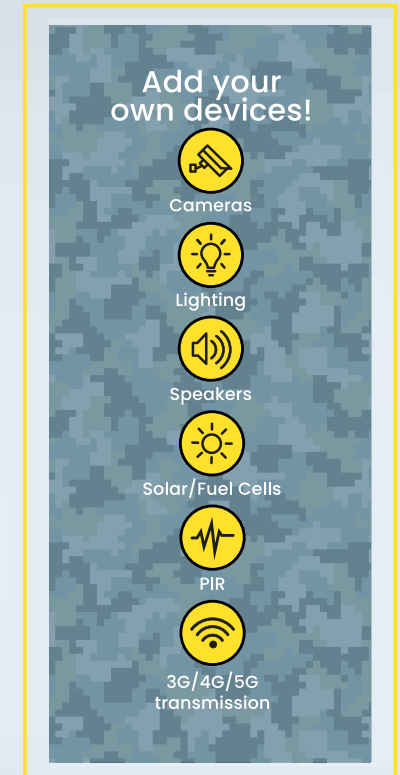
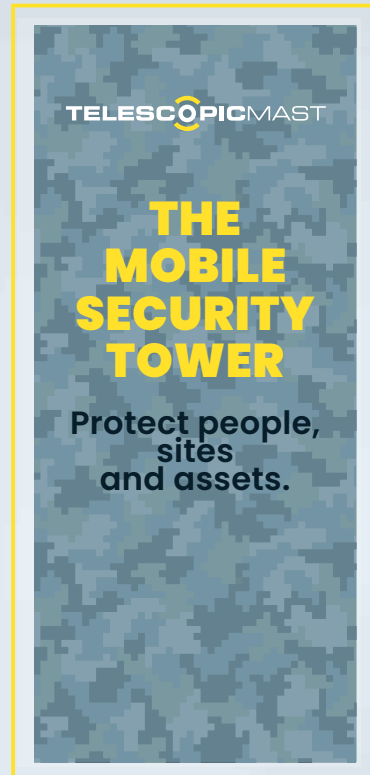

TELESCOPICMAST

Creating global site security



TelescopicMast
Ruwekampweg 2D
5222 AT 's-Hertogenbosch
The Netherlands
phone: + 31 634 185 799

For more information,
please send an e-mail to:
info@telescopicmast.com

Scan the QR code
to watch
our Mobile Security Box in action

